

BCP BW CIRCULATING PUMP

Horizontal single stage single suction

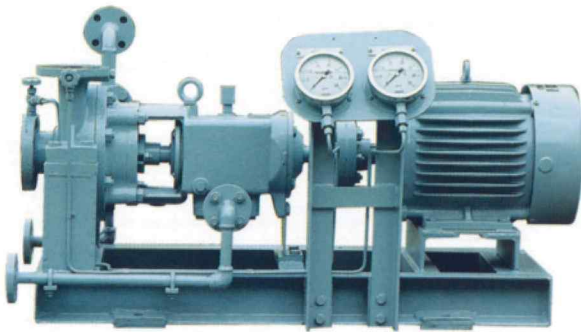

■ Applications

Boiler water circulating pump
for exhaust gas boiler

■ Principal Particulars

Item	Model	BCP 50AX	BCP 65A
Rotation		Clock viewed from driver end	
Suction bore(mm)		50	65
Discharge bore(mm)		40	50
ball bearing		7309BDB + 6309	
Service life(hr)		Abv. 60,000hr	
Amount of LO filled		0.2(ISO VG-68)	
Stuffing box seal		Throttle bush & packing	
Weight (kg)		64	67
Water filled casing(kg)		2	2

■ Standard Materials

Part No.	Name Of Part	REQ. NO. FOR 1PUMP	MATERIAL	
			Name	KS
102.1	VOLUTE CASING	1	CAST STEEL	aSC46
161.1	CSAING COVER	1	CAST STEEL	SC46
165.1	JACKET COVER	1	CAST IRON	GC200
165.2	JACKET COVER	1	CAST IRON	GC200
183.1	SUPPORT	1	STEEL	SS41
210.1	SHAFT	1	STAINLESS STEEL	STS304
230.1	IMPELLER	1	STAINLESS STEEL	SSC13
321.1	BALL BEARING	1	BEARING STEEL	SB2
321.2	BALL BEARING	1ST	BEARING STEEL	SB2
330.1	BEARING HOUSING	1	CAST IRON	GC200
360.1	BEARING COVER	1	CAST IRON	GC200
382.1	BEARING CASE	1	CAST IRON	GC200
400.1	GASKET	1	NON ASBESTOS	
400.2	GASKET	1	NON ASBESTOS	
400.3	GASKET	1	OIL PAPER	
400.4	GASKET	1	OIL PAPER	
400.5	GASKET	1	NON ASBESTOS	
412.1	O-RING	1	EPDM	
412.2	O-RING	1	EPDM	
421.1	OIL SEAL	1	NBR	
421.2	OIL SEAL	1	NBR	
452.1	PACKING GLAND	1	CAST IRON	GC200
461.1	PACKING	4	CARBON FIBER	
502.1	CASING WEAR RING	1	STAINLESS STEEL	SSC13
507.1	THROWER	1	NBR	
523.1	SHAFT SLEEVE	1	STAINLESS STEEL	STS304
542.1	THROTTLE BUSH	1	CARBON	
606.1	BALANCE CASE	1	CAST STEEL	SC46
639.1	OIL SIGHT GAUGE	1	PLASTIC	
673.1	AIR RELEASE FILTER	1	ALUMINUM + SS41	AL + SS41
727.1	RETURN PIPE FLANGE	1	STEEL	SS41
861.1	COUPLING HALF	1	CAST IRON	GC200
906.1	EYE BOLT	1	STEEL	SS41
922.1	IMPELLER NUT	1	STAINLESS STEEL	STS304
923.1	BEARING NUT	1	STEEL	SS41
931.1	BEARING LOCK WASHER	1	STEEL	SS41
932.1	RETAINING RING	1	SPECIAL STEEL	SK5M
936.1	PLAIN WASHER	1	STAINLESS STEEL	STS304
937.1	SPRING LOCK WASHER	1	STAINLESS STEEL	STS304
940.1	IMPELLER KEY	1	STAINLESS STEEL	STS304
940.2	COUPLING KEY	1	CARBON STEEL	SM45C

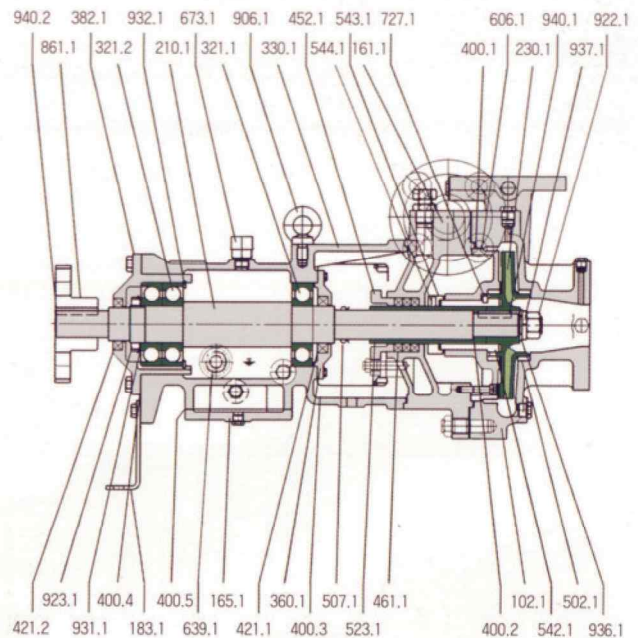

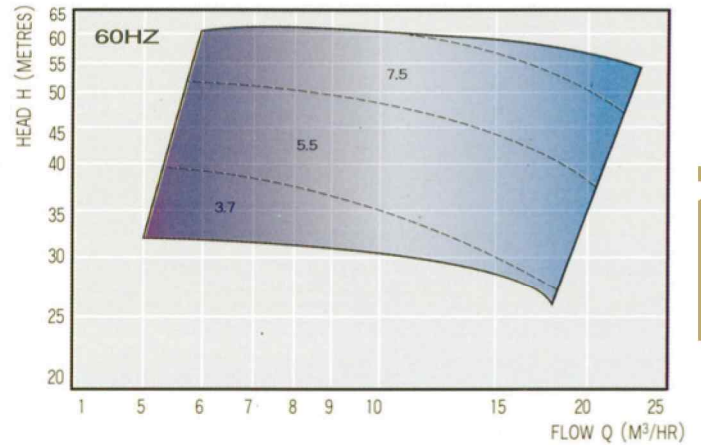
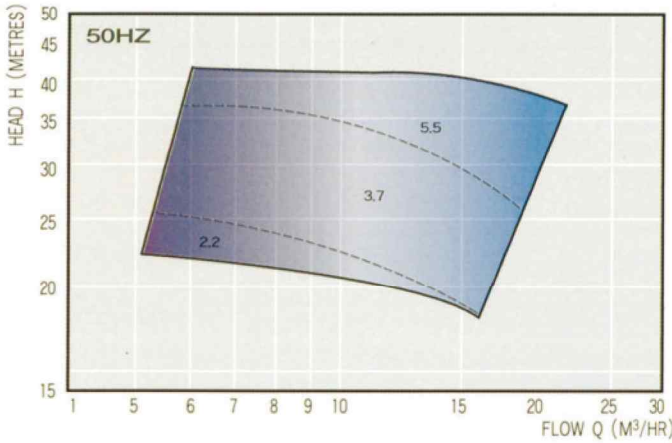

■ **Stuffing Box Seal**

A throttle bush is provided at the front of the stuffing box. The high temperature and high pressure water, while it passes through the minute clearance between bush and shaft sleeve, incurs the pressure reduction and is led to condenser or cascade tank. Further, carbon fibre packing is provided of the outer side to prevent leakage completely.

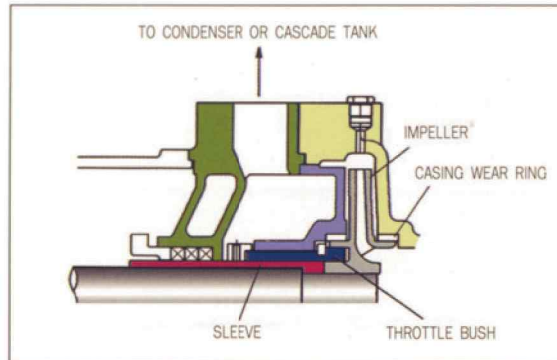

In general, for the purpose of detecting the content of salt the cascade tank is provided with a salinity indicator which issues alarm according to the degree of electric conductivity.

Since the boiler water cleaning agent has high electric conductivity, in case the water leaking from the pump is led to the cascade tank, it must be released at a point remote from the salinity indicator.

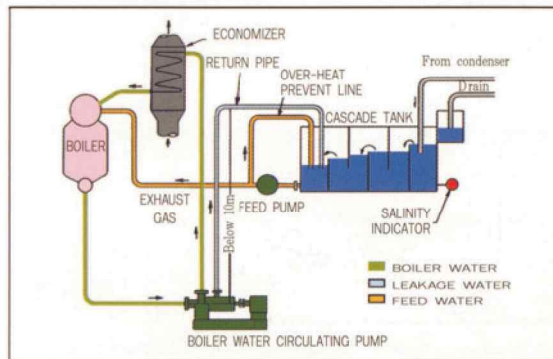

The height of the cascade tank to which the water leaking from the pump is led must be limited to less than 10m in order to reduce pressure on the packing.

■ Bearing & Lubrication

It is so designed that axial thrust force becomes almost zero at the normal condition. But when used at other conditions, axial thrust force occurs. Accordingly, on the casing side one deep groove type ball bearing and on the coupling side two angular contact type ball bearing are provided to meet with this force. Self-lubrication system is adopted in which part of the bearings is immersed in oil.

■ Standard Accessories

- Baseplate.....1
- Discharge pressure gauge.....1
- Suction pressure gauge.....1
- Gauge stand.....1
- Gauge root valve.....2
- Coupling cover.....1

■ Standard Spare Parts

- 1 pump set of the following spare parts is supplied for 1 ship
- Ball bearing
- Gland packing
- Coupling bolt, nut & washer, rubber ring
- Complete set of rotating element(if required)

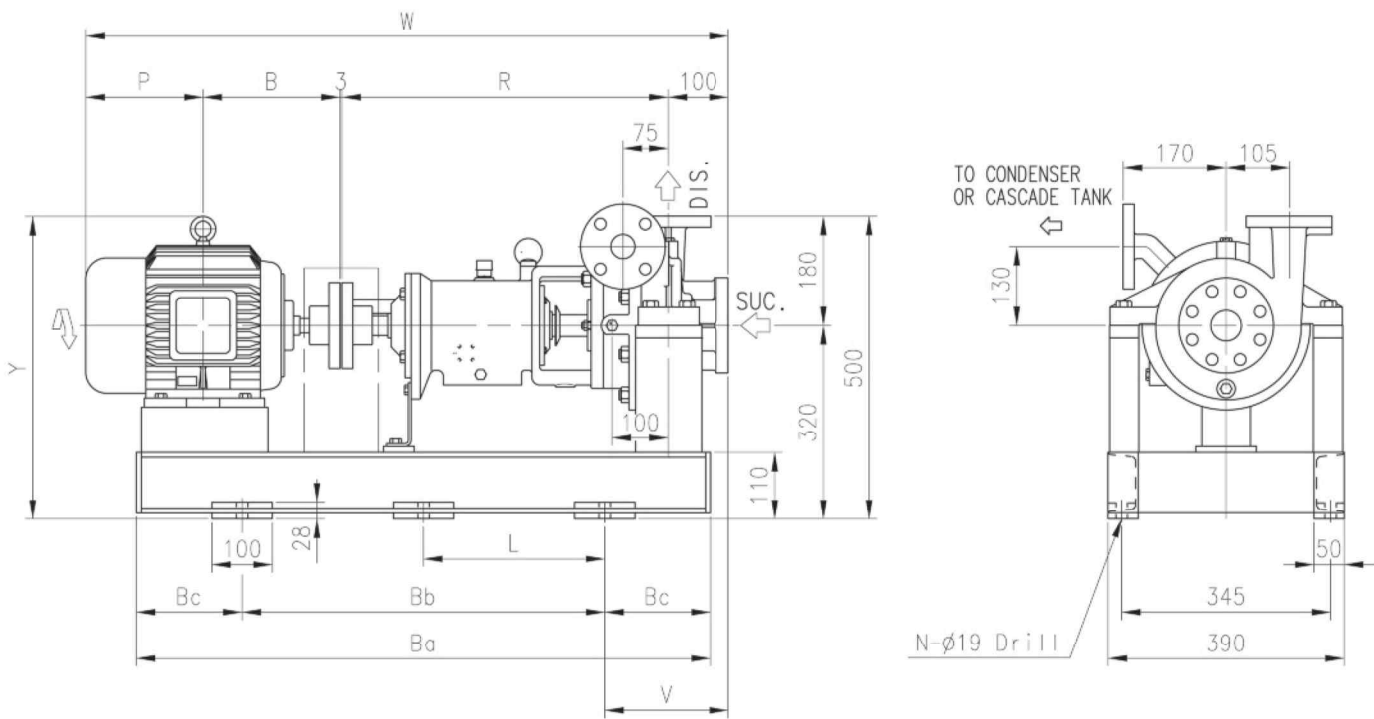

Model	MOTOR (2P)	Dimensions (mm)											WEIGHT(kg)			
		W	P	B	R	Y	Bc	Bb	Ba	L	V	N	PUMP	MOTOR	BASE	TOTAL
BCP 50AX	3.7	1031	189	200	539	478	175	600	950	-	210	4	64	45	55	164
	5.5 7.5	1102	221	239	539	503	200	600	1000	-	235	4	64	72	55	191
BCP 65A	5.5 7.5	1103	221	239	540	503	200	600	1000	-	235	4	64	72	55	191
	11 15	1249	283	323	540	528	125	600	1050	400	160	6	64	125	55	244